

Level gauge

MLT 6110/6130/6260 mipromex[®]



- Continuous fill level measurement with control function
- Evaluation for impedance probes
- Active product compensation with product monitoring
- Menu guidance in 3 languages
- Commissioning procedure
- DIN rail or wall mounting

Use

Universal measuring unit for fill level measurement or adjustment for continuous operation in laboratories, production plants or storage tanks. Continuous level measuring with 100% calibration to:

- ▼ Key press
- ▼ Archives for product names and measured values
- ▼ Via level differential measurement
- ▼ Limit value of external digital input
- ▼ by level rise for run-down tanks

Automatic 100% calibration by means of product compensation without commissioning. The 2nd Measuring circuit serves the automatic measuring span. Calculation by means of reference measuring probe. The exact level can thus be monitored in the case of changing media or temperatures.



Overview

- ▼ MLT 6110 1 measuring circuit with one active analogue output and two limit values (OC)
 - ▼ MLT 6130 1 measuring circuit with one active analogue output and two limit values (relay)
 - ▼ MLT 6260 2 measuring circuits with one active analogue output each; Measuring circuit 1 with two limit values (relay); Measuring circuit 2 for product compensation
- continuous fill level measurement with bar probe
 - Product-compensated fill level measurement
 - Parameterisation in languages: D / F / E
 - Device data and item/TAG no. storage
 - Measured value processing in microprocessor technology
 - Film keypad with graphic display
 - 19" plug-in cartridge 3 HE/12 TE (European format)
 - Supply 24 V AC 50/60 Hz/ DC independent of polarity
 - Analogue output 4 - 20 mA with galvanic isolation max. load 750 Ohm active (not Ex)
 - Fault message programmable on analogue output
 - Fault indication Time/Date
 - 2 LV relay outputs max. 2A/30VDC
 - Output and limit value mA simulation
 - 1 or 2 measurement inputs for MTI probe connections, max. cable length approx. 200 m (<120 nF)
- Ex version: Gas II (2) G [Ex ia Gb] IIC
Staub II (2) D [Ex ia Db] IIIC;
- SEV 09 ATEX 0132; EMC STS 024 CE 1254

Basic function

The mipromex® MLT fill level measuring unit can be equipped with one or two measuring circuits. One or two measuring signal processings are activated depending on the type.

The pulse signal transmitted from the MTI transmitter module is converted into an offset-compensated, filtered pulse value and, in function of the entered or calculated measuring span, converted into level, volume or weight and into a 4-20 mA signal.

The indication on the graphic display visualises the pulse value, % value, units in mm/cm/m/ml/l/hl/cm³/dm³/m³/g/kg/t/in/feet/ga/lb/oz/gt, as well as the mA output signal. The offset range can be set between 10 and 1000 pulses (zero point e.g. at 60 ±5 pulses). The automatic probe calibration can be activated via the parameters when the mains is switched on.

The product-dependent measuring span can be accepted via four calibration options. The fill level, volume or weight is displayed in the set unit of measurement and is available as a 4-20 mA signal at the analogue output. For the MLT 6260 product-compensated fill level measurement, the product-dependent measuring signal is also available as 4-20 mA at the second analogue output.

The volume in function of the fill level is calculated by means of linearisation curves for horizontal cylindrical tanks.

Parameter entries are menu-guided and type-dependent. Inactive positions are hidden during the commissioning procedure.

The parameters can be stored and reloaded. The device is equipped with three digital inputs, which can be used for calibration purposes.

For the fill level and volume monitoring, two further relays are available with alternating contact, each with Low and High function as well as adjustable on/off time delay and fail-safe setting. Error messages are visualised with time, date and error type.

Measuring circuit

A measuring probe with MTI transmitter module in the probe head is connected to the mipromex® MIQ by means of a shielded 2-core cable. A potential equalization line must be installed between the plant and control room grounds.

Measuring principle

Impedance measurement; dependent on electrical conductivity and dielectric constant.

Wiring

2-core cable 0.75 mm² twisted CY/EIG, cable length up to 200 m or max. C= 120 nF / R = 30 Ohm line impedance

Connection

All aquasant® on-site electronic units for impedance measurement can be connected.

Function change

MLT 6110/6130:

Continuous level measuring with analogue output and two limit values (relay) for Low/High. Continuous level measuring with 100% calibration to:

- ▼ Key press
- ▼ Archives for product name and measured values, selectable via three digital inputs (BCD rotary switch)
- ▼ Via level differential measurement
- ▼ Limit value of external digital input
- ▼ by level rise for run-down tanks

MLT 6260:

Automatic 100% calibration through product compensation or by means of internal limit value 3 of the 2nd measuring circuit, which has not been calibrated.

Function

The electrode system of a bar probe, surrounded by product, changes the impedance in function of the dielectric properties and conductivity of organic products and aqueous solutions, as well as the immersion depth of the active measuring electrodes.

The measured impedance sum signal is converted directly by the MTI transmitter module into a normed signal and is transmitted as pulse packages to the analogue transmitter mipromex® MLT.

Entry of limit values and linearisation curves for volume indication of horizontal cylindrical tanks in accordance with plant specifications.

MLT 6110/6130:

There are several calibration alternatives available for measuring the fill level height: (no product changes during measurement)

Acceptance of measured value at current known fill level and calculation of measuring span with the press of a key. This requires the current level to be entered in the currently active unit.

External limit value via digital input D1 (see Section 7.4) with entry of fill level at limit value probe and conversion to 100% corresponding to unit mm, m, ml, l, m³, kg, t in the case of limit value being exceeded or undershot, but not in

the case of supply voltage, automatic acceptance of 100% measured value; calibration by level rise only equalizing on gradient (no calibration for fill level stop).

Calculation of measuring span in function of a fill level difference. Measured value storage for Level 1 and Level 2 and entry of level difference)

Up to 50 product measured values can be stored with names on the device. Up to seven products can be selected from the PCS via three digital inputs in the mipromex®. One 4-20 mA analogue output and two fill level limit value relay outputs are available.

MLT 6260:

Product-compensated measurement with 2 measuring circuits. Parameterised for a fill level probe as in factory. Connect level probe and measure.

Alternatively, internal calibration is possible via a limit value. With an internal limit value 3 of measuring circuit 2; entry of fill level at limit value probe and conversion to 100% corresponding to unit mm, m, ml, l, m³, kg, t... in the case of limit value being exceeded or undershot, but not in the case of supply voltage.

One 4-20 mA analogue output for fill level and measured product values, as well as two fill level limit values, are available for measuring circuit 1.

Product-compensated measurement with MLT 6230: (Software corresponding to MLT 6260)

Only one 4-20 mA analogue output and two fill level limit value relay outputs are available for measuring circuit 1.

Connection circuit board for 19" rack, Monorack

Cage Clamp® terminals for 0.08–2.5 mm² cable cross section, stripping length 5–6 mm / 0.22 in (without cable end sleeve), are mounted using a special tensioning tool.

Colour coding:

The fail-safe field circuit is connected to the **blue** terminals. It may be guided into the hazardous area with connecting cables as per DIN EN 60079-14.

The **black/orange** terminals are polarity-dependent current inputs and outputs.

Dimensions: H x W x D 137 x 77 x 210 mm / for Eurocard 3 HE/12TE Depth 60 mm

Connection to: mipromex® microprocessor device

Article no.: 02.03.18.011

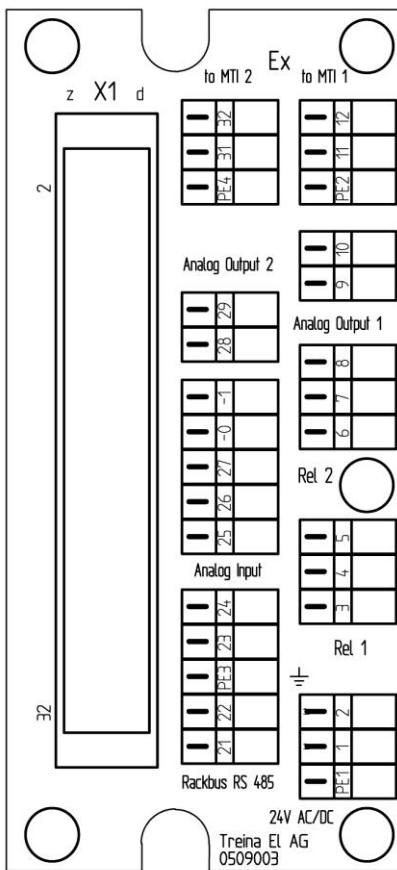

- | | |
|---|------------|
| PE1 Erdung | FI32: d/z6 |
| 1. Speisung 24 V AC/DC 50/60 Hz (polungsunabhängig) | FI32: z30 |
| 2. Speisung 24 V AC/DC 50/60 Hz (polungsunabhängig) | FI32: d30 |

	Relais	Optokoppler	
3.	1 NO	Ausgang E-	FI32: z24
4.	1 COM	Ausgang C+	FI32: d24
5.	1 NC	-	FI32: z22
6.	2 NO	Ausgang E-	FI32: z16
7.	2 COM	Ausgang C+	FI32: d16
8.	2 NC	-	FI32: z14

- | | |
|-------------------------------|-----------|
| 9. MK1 Analogausgang 1 - | FI32: d14 |
| 10. MK1 Analogausgang 1 + | FI32: z12 |
| 11. MK1 MTI 1 K1 | FI32: z2 |
| 12. MK1 MTI 1 K2 | FI32: d2 |
| 21. Rackbus RS 485 A | FI32: z32 |
| 22. Rackbus RS 485 B | FI32: d32 |
| 23. Analog-Eingang - | FI32: d18 |
| 24. Analog-Eingang + | FI32: d12 |
| 25. Digital-Eingang 3 (+24 V) | FI32: d10 |
| 26. Digital-Eingang 2 (+24 V) | FI32: z10 |
| 27. Digital-Eingang 1 (+24 V) | FI32: d8 |
| -0 Digital input D1-3 (0 V) | FI32: z8 |
| -1 Digital input D1-3 (0 V) | FI32: z8 |
| 28. MK2 Analogausgang 2 - | FI32: d22 |
| 29. MK2 Analogausgang 2 + | FI32: z20 |
| 31. MK2 MTI 2 K1 | FI32: z4 |
| 32. MK2 MTI 2 K2 | FI32: d4 |

Mounting/Installation:

The 19" cartridge is used in a MRM Monorack for DIN rail or wall mounting.

The connection board with FI32 female multi-point connector can also be installed in table-tops or 19" racks. For Ex applications, the connection boards are different (female multi-point connectors are coded).

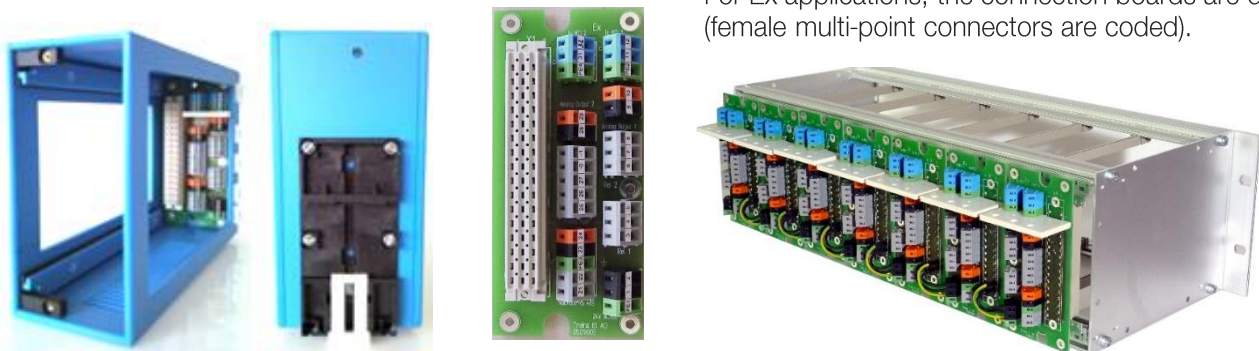

Connections to FI32 female multi-point connector MLT 6130

Microprocessor device with one measuring circuit input | Connections to FI32 female multi-point connector

Electrical data

Euro plug-in print pin assignment 24 V version

Switchpoint 1 for measuring circuit 1 FSL (Fail Safe Lo) L Alarm
 Relay de-energised (Measured value < Limit value)
 Switchpoint 2 for measuring circuit 1 FSH (Fail Safe Hi) H Alarm
 => for dynamic batch separation, FS setting is inactive
 Relay de-energized (Measured value > Limit value)

Technical error: Switching levels analogue output as per parameterisation, relay de-energised
 Fault message programmable in 0.1 mA increments; 0.5...3.9 / 20.1...22 mA

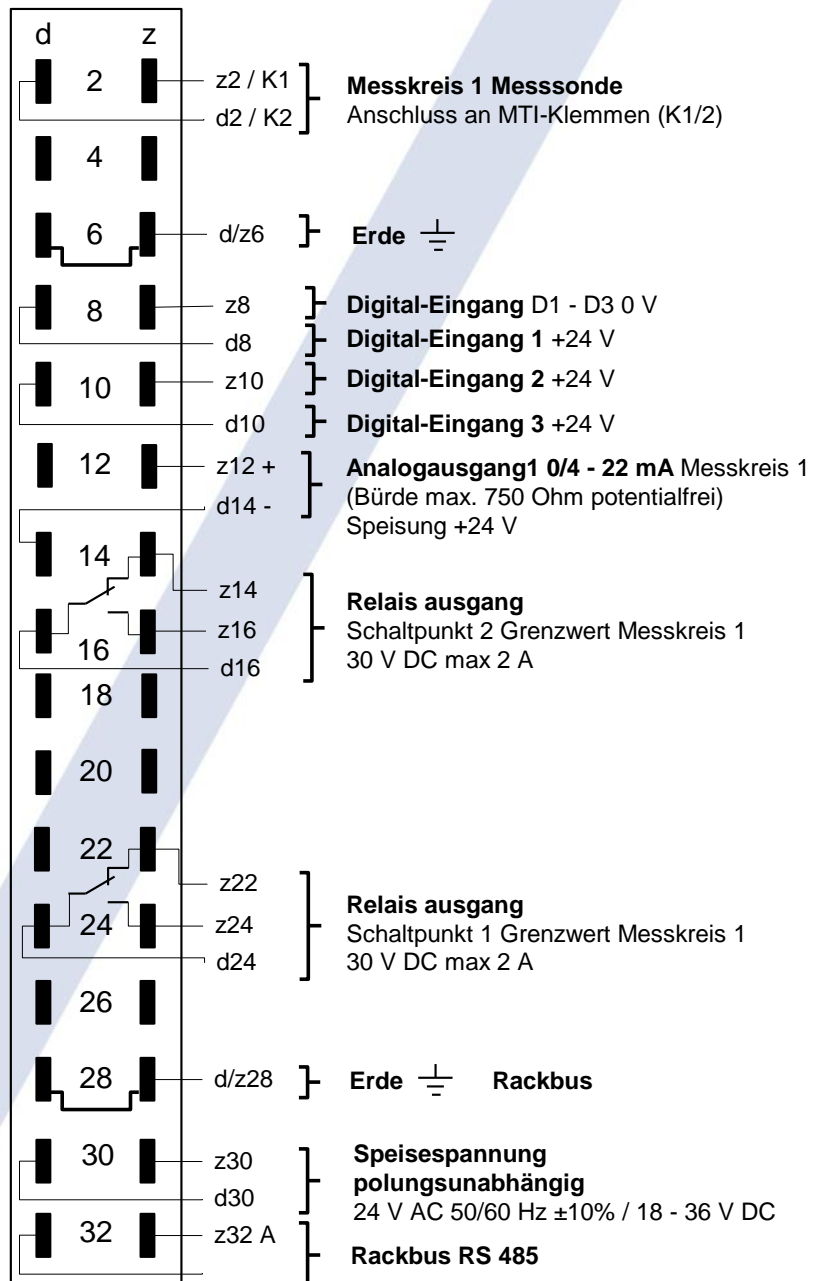

Connections to FI32 female multi-point connector MLT 6260

Microprocessor device with two measuring circuit inputs | Connections to FI32 female multi-point connector

Electrical data

Euro plug-in print pin assignment 24 V version

Switchpoint 1 for measuring circuit 1 FSL (Fail Safe Lo) L Alarm
 Relay de-energised (Measured value < Limit value)
 Switchpoint 2 for measuring circuit 1 FSH (Fail Safe Hi) H Alarm
 => for dynamic batch separation, FS setting is inactive
 Relay de-energised (Measured value > Limit value)

Technical error: Switching levels analogue output as per parameterisation, relay de-energised
 Fault message programmable in 0.1 mA increments; 0.5...3.9 / 20.1...22 mA

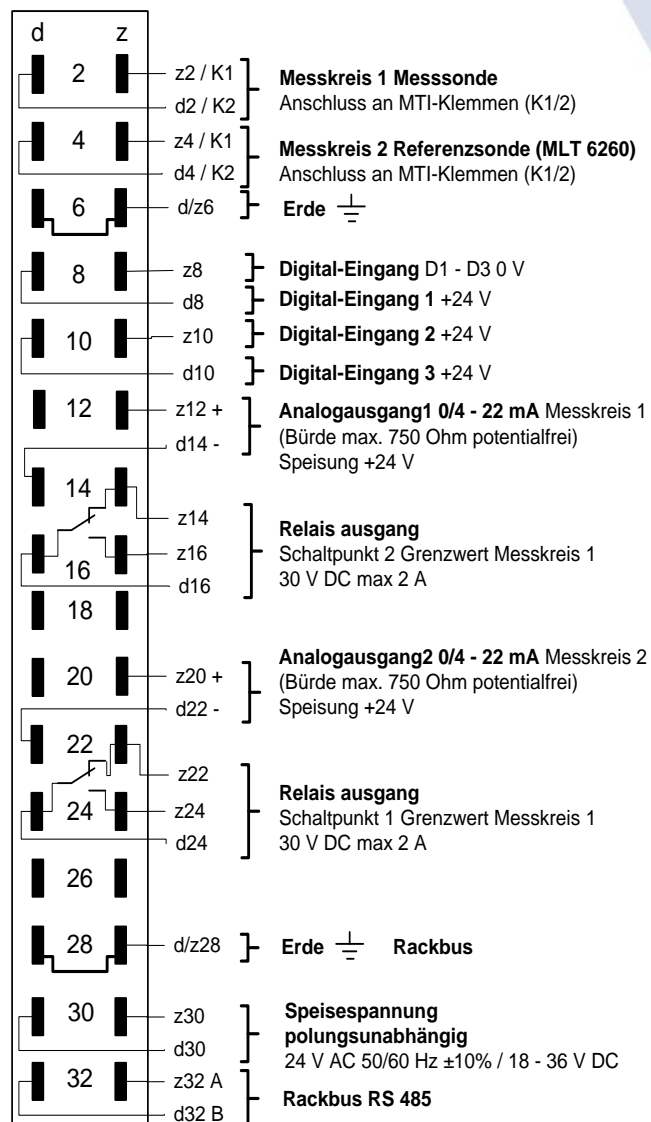

Earthing for microprocessor devices and probes

Earth-related measuring must be earthed in accordance with Ex regulations.

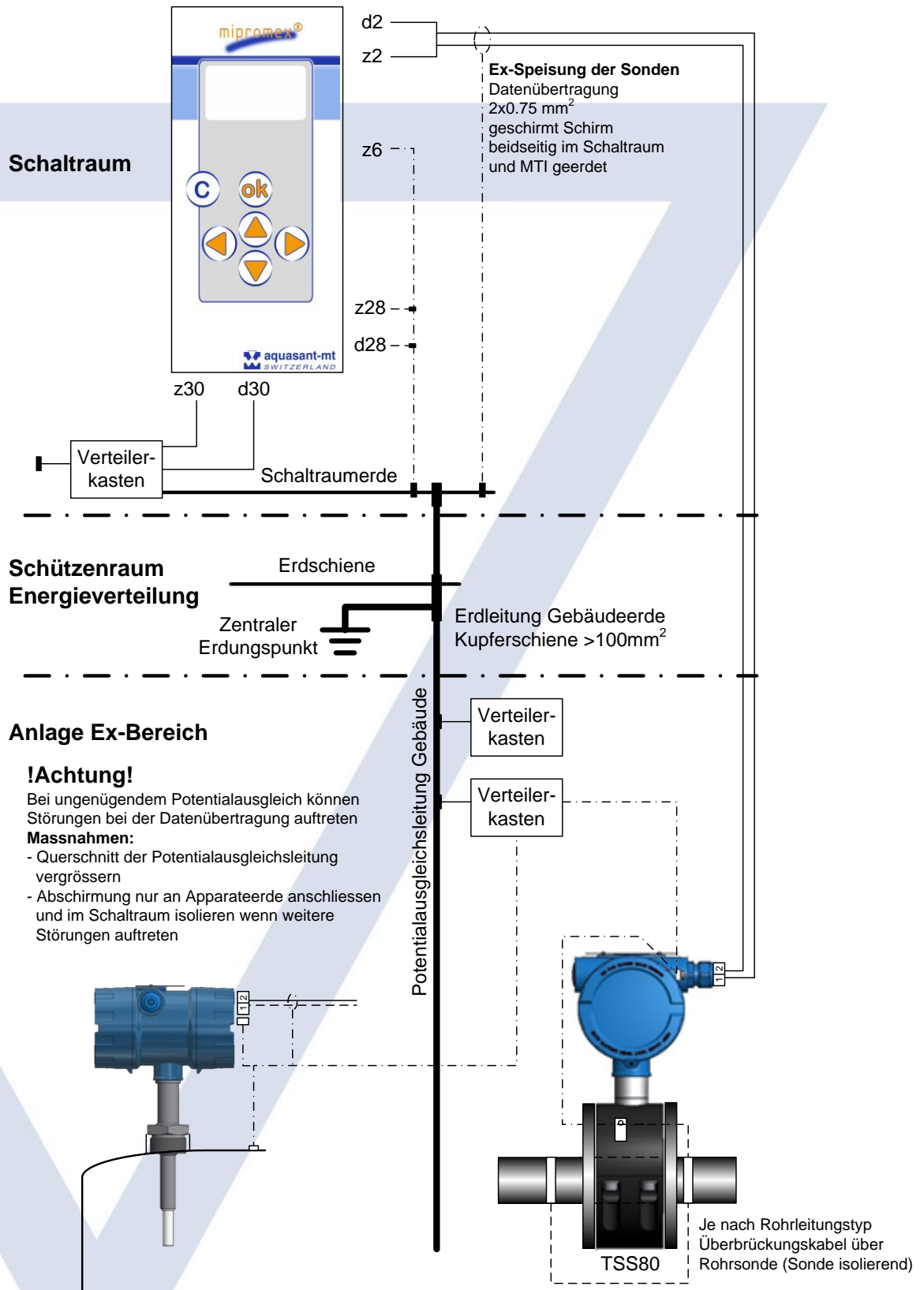

Technical data

Design type

Plug-in electronics with square stainless cover in protective housing, with HF connection

19" plug-in module with aluminium-steel housing; IP 20

Mounting

MR 7 19" rack; 3 HE (European format)

MRM II monorack; plastic housing for DIN rail or wall mounting. Front panel mounting with BOPLA housing.

Compact or table-top for laboratory

Function

Interface layer measuring device with fail-safe supply for one or two MTI xx measurement transducers.

- Continuous level measuring
- Menu-guided multilingual device communication
- Commissioning procedure
- 1/2 analogue and 2 digital outputs

Operation/Display

Front panel with film keypad with graphic LCD display, backlit, 6 push buttons for entering calibration data and parameters

Data backup in case of mains failure

Battery buffer max. 10 years. Parameter storage in case of battery failure

Dimensions

Heights 3 HE; width 12 TE

Front panel: Height x Width 128 x 61 mm

Plug-in module: Height x Width x Depth 100 x 60 x 160 mm

7 plug-in modules can be mounted per 19" rack

Weight

MLT 6130: 690 g / MLT 6260: 705 g

Supply voltage

24 V DC/AC 50/60 Hz (22-26 VAC) / (18-36 VDC), independent of polarity

Start-up current

Short-time (1 ms) approx. 1 A

Power consumption

MLT 6130 approx. 3.4 VA (I = 140 mA) / MLT 6236 approx. 4 VA (I = 200 mA)

Fuses

8.5 x 8.5 mm miniature fuse MST 400 mA

Hazardous area supply/Signal transmission

[Ex ia] IIC, modulated pulse supply signal

Open circuit voltage $U_o \leq 18.9$ V

Short-circuit current $I_o \leq 49$ mA

Power $P_o \leq 231$ mW output characteristic linear

Ex d ia, modulated pulse supply signal

Open circuit voltage $U \leq 19.3$ V

Short-circuit current $I \leq 75$ mA

Signal wiring circuit Ex ia IIC

Max. outer inductance $L_o \leq 10$ mH

Max outer capacity $C_o \leq 180$ nF

Signal transmission

1 or 2 measuring circuits, modulated pulse supply signal

Signal wire short-circuit

max. current consumption MLT6130: 160 mA / MLT 6260: 280 mA

Ambient temperature

0 °C ... +45 °C

Storage temperature

-20 °C ... +45 °C, ideally +20 °C

Measuring range / Data display, processing

0 – 3700 pulses / Transmission of MTI 400 ms, internal processing mipromex® 20 ms, approx. 3 measurements/second

Switching hysteresis

1 pulse corresponds to 0.028 pF for measuring range 100 pF

Connection

FI male plug 32 poles, coding possible (Ex version)

Relay output

2 relays of 1st Measuring point with one switchover contact for the limit value, example: Min./max. deviation, min. or max. safety selectable. Switching voltage 30 Vdc / 2 A, I/O=2kV, -40 to +85 °C
One relay each for two-channel devices

Switching voltage relay – output

30 V DC

Continuous current relay – output

2 A

Breaking capacity relay – output

60 W

Analogue output

1 active 4–20 mA output, max. load 750 Ω, non-Ex, with potential separation, technical failure 0.5–4 / 20–22 mA adjustable

Interface

RS 232 / RS 485 (only for firmware update)

Monitoring

Self-monitoring measuring system: defective probe, short-circuit/interrupted Ex-supply (wire break fuse); measuring range; mains failure and mipromex® malfunctions

Te_s Ex

Gas II (2) G [Ex ia Gb] IIC

Staub II (2) D [Ex ia Db] IIIC

II (2) G / II (2) D (Probe [Ex d ia] IIC)

RL 2014/34/EU

Test report no.: 08-IK-0396.01 with extension 1

Device also available without hazardous area protection mipromex® must be installed outside the hazardous area.

Fail-safe hazardous area connection:

MTI transmitter module ... In protective housing or S**; K**; F** bar probes

Tested for EMC, STS 024 Report No. 990102WS complies with EN 1127-1 : 20011

EN 61000-6-2 2005 EN 6100-6-4 : 2007

EN 60079-0 : 2012 EN 60079-11 : 2012



Fault messages

Error messages are visualised on the display with time, date and error type.

Fault messages can be programmed on the analogue signal in the ranges of 0.5 – 4.0 mA and 20.0 – 22.0 mA, in increments of 0.1 mA.

In the event of a fault, the limit value outputs are de-energised.

Technical error:

All mipromex® microprocessor devices are equipped with a diagnostic system, which facilitates the error search and helps to rectify faults more quickly.

mipromex® technical errors which require the device to be sent to aquasant® for repair:

- ▼ Flash memory checksum verification failed

In the case of repeated errors, send device in for repair!

- ▼ Flash memory failed

Flash is defective; send device in for repair!

- ▼ Low battery: Battery is discharged and must be replaced

Battery change; send device in for repair!

- ▼ Programme memory check failed

Microprocessor card is defective; send device in for repair!

Data error:

- ▼ Measured value undershot: mA output changes to the value programmed in menu item 8.3! Relays drop out.

Possible cause: Cable break, misaligned on-site electronic unit MTI

- ▼ Measured value exceeded: mA output changes to the value programmed in menu item 8.3! Relays drop out.

Possible cause: Measured value is greater than 3750 pulses, misaligned on-site electronic unit MTI

